

EMERGENCY IP65 BULKHEAD 3HR MAINTAINED WITH SELF ADHESIVE LEGEND

- Materials: Polycarbonate body and diffuser
- 2.4V 4.5Ah Ni-Cd batteries
- Complete with white LED
- DC or AC/DC operated
- Latest ISO 7010 format legend
- Viewing distance = 24m
- Can also be used as non-maintained
- Fixed output integrated driver

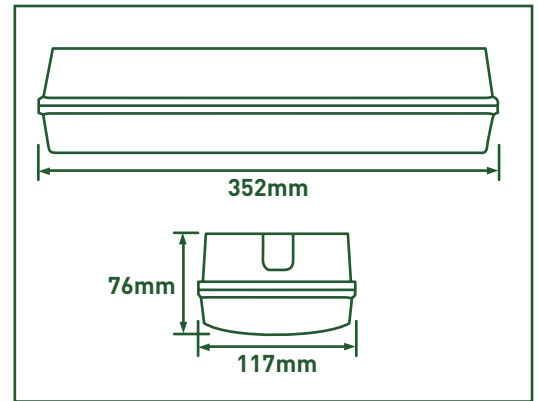

3 year
Standard
WARRANTY



1 year
on site
WARRANTY

3 years standard and 1 year onsite warranty available in the UK. Rest of the world may vary, please ask your local distributor for more information.



CAT NO.	LUMINAIRE LUMENS	WATTAGE
LEMBHM3	102	3.8W



STANDARDS

EN 60598-1	Luminaires - General requirements
EN 60598-2-22	Luminaires - Emergency
EN 61347-1	Lamp controlgear - Part 1: General and safety requirements
EN 61347-2-13	Lamp controlgear - Part 2-13 : Particular requirements for d.c. or a.c. supplied electronic controlgear for LED modules
EN 55015	Limits and methods of measurement of radio disturbance characteristics of electrical lighting and similar equipment
EN 61547	Equipment for general lighting purposes - EMC immunity requirements
EN 61000-3-2	Electromagnetic compatibility (EMC) - Part 3-2: Limits - for harmonic current emissions
EN 62471	Photobiological safety of lamps and lamp systems
2002/96/EC	Waste Electrical & Electronic Equipment (WEEE)
2011/65/EU	Restriction of the use of certain Hazardous Substances in EEE (RoHS)
[EC] No 1907/2006	The Registration, Evaluation, Authorisation and Restriction of Chemicals (REACH)

Tech Help Line
UK - **0845 194 7584**
Non UK - **+44 (0)1952 238 100**

Supplied by Nexus Industries Ltd
Nexus Distribution Centre, Stafford Park 1
Telford, Shropshire, TF3 3BD

Visit our website at
www.luceco.uk